

PERFORMANCE ANALYSIS OF A SIMPLIFIED MULTILEVEL CONVERTER FOR OFF-GRID SOLAR SYSTEMS

#1 **Gandham Vennela**, *Department of EEE*,

#2 **Mr.M.Ramana Reddy**, *Associate Professor, Department of EEE*,

Vaageswari College of Engineering(Autonomous), Karimnagar, TG.

ABSTRACT: This investigation evaluates the functionality of a simplified multilevel converter for off-grid solar systems, with the objective of delivering a dependable and efficient DC-AC power conversion with a reduced level of circuit complexity. The converter that is recommended utilizes a switch methodology that is more efficient and utilizes fewer components to enhance voltage levels while simultaneously decreasing total harmonic distortion (THD) and switching losses. The system's efficiency, voltage gain, and output waveform quality are evaluated in various solar irradiation and load scenarios. The converter is suitable for independent and remote solar applications, as it generates high-quality power and functions consistently and efficiently without the need for large transformers, as indicated by the simulation findings. The research suggests that the simplified multilevel converter is a cost-effective and efficient alternative for the generation of sustainable off-grid power.

Keywords: *Multilevel Converter, Off-Grid Solar System, DC-AC Conversion, Total Harmonic Distortion (THD), Voltage Gain, Power Electronics, Renewable Energy,*

1. INTRODUCTION

The demand for sustainable and reliable energy sources, particularly in remote and rural regions with minimal or no utility access, has resulted in an increase in the implementation of off-grid solar power systems. Solar photovoltaic (PV) systems have emerged as a viable alternative due to their ability to produce pure energy and their low operating costs. The challenge of efficient power conversion remains a critical concern, however. The direct current output from solar panels must be converted into usable alternating current electricity in order to satisfy the majority of electrical needs. As a result, it is necessary to create converter topologies that are more intricate and that satisfy the standards for high efficiency, reliability, and power quality.

In recent years, there has been a substantial increase in interest in the ability of multilevel converters to produce high-quality output voltage with minimal harmonic distortion and electromagnetic interference. Multilevel converters generate superior voltage profiles by employing multiple voltage levels to generate the output waveform, in contrast to conventional two-level inverters. This results in enhanced system efficacy and reduced stress on power electronic components. In contrast, conventional multilevel converter topologies typically involve a greater number of components, complex circuit configurations, and sophisticated regulatory mechanisms.

It is imperative to evaluate the performance of power converters in order to guarantee the consistent operation of off-grid systems under a variety of climatic and load conditions. System efficiency and output quality can be significantly impacted by fluctuations in temperature, load, and solar radiation. In order to determine the converter's suitability for standalone solar applications, it is imperative to conduct a thorough assessment of variables including efficiency, voltage gain, total harmonic distortion, and dynamic responsiveness.

2. LITERATURE SURVEY

Hassan, M., & Brooks, T. (2025): The research suggested that off-grid solar systems are enhanced by simplified multilevel converters, which provide effective voltage conversion with reduced circuit complexity. The paper suggests an enhanced switching methodology to mitigate harmonic distortion and switching losses. The results demonstrate that the converter is suitable for remote and independent photovoltaic applications due to its improved voltage regulation and increased system efficiency.

Nguyen, K. T. (2024): The efficacy of multilayer converters in off-grid solar applications is investigated in this study under a variety of irradiance and load conditions. The simulation assesses parameters including efficiency, voltage gain, and total harmonic distortion (THD). The research demonstrates that converter topologies that are simplified can provide dependable output performance while simultaneously reducing system costs and hardware requirements.

Almeida, R., & Costa, P. (2023): The objective of this research is to create a compact multilayer converter structure for solar energy systems. The authors introduce a control technique that optimizes switching operations to reduce losses and improve waveform quality. The efficacy of the proposed design in attaining dependable DC-AC conversion and improved energy efficiency for off-grid applications is demonstrated by the experimental and computational results.

Khan, F., & Ibrahim, S. (2022): This paper examines a variety of multilayer converter configurations for autonomous solar systems, with an emphasis on the enhancement of performance and reliability. Traditional and refined designs are contrasted in the study, which demonstrates that a reduction in components results in easier implementation and reduced maintenance, all while maintaining the quality of the output voltage.

Lopez, J., & Park, S. (2021): This paper provides a thorough assessment of the efficacy of fundamental multilayer converters for off-grid solar applications. The authors suggest a model that incorporates intricate switching strategies to improve voltage enhancing capabilities and minimize distortion. The findings suggest that the system is more stable, the power conversion is more effective, and the system is suitable for rural electrification and isolated energy systems.

3. RESEARCH METHODOLOGY

Simulations are employed to assess a simplified multilayer converter for off-grid solar systems. The methodology is utilized across many operating scenarios and encompasses system design, modeling, control implementation, and performance assessment.

System Modeling

Three photovoltaic (PV) modules with different voltage levels (133.3 V, 266.6 V, and 400 V) are combined to produce a multilevel arrangement in the suggested system. These solar sources are coupled in a systematic way to produce a graded output voltage capable of powering AC loads.

Simulation Setup

MATLAB/Simulink is employed to accurately model the photovoltaic properties and converter functions during the system's development. The subsequent standard conditions are employed during the exercise:

- Temperature: 25°C
- Solar irradiance: 1000 W/m²
- PV arrays connected in parallel configuration

Converter Design

A multilayer inverter architecture with a reduced number of switches is employed to simplify the circuit. Prior to the conversion of solar energy into alternating current, a DC–DC boost converter elevates and regulates its voltage.

The duty cycle of the boost converter is delineated as follows:

$$D = 1 - \frac{V_{in}}{V_{out}}$$

Control Strategy

An effective switching technique generates many voltage levels, reaching a maximum of seven. The switching devices operate in tandem to achieve accurate voltage generation, reduced switching losses, and enhanced waveform quality.

Performance Parameters

The subsequent criteria are employed to evaluate the system's functionality:

- Total Harmonic Distortion (THD)
- Output voltage and current
- Voltage gain
- Conversion efficiency
- Power quality

4. SIMULATION RESULTS

The image illustrates the proposed system, which was created using the MATLAB/Simulink software. This system employs three photovoltaic systems that generate direct current voltages of 133.3 V, 266.6 V, and 400 V. The temperature remains constant at 25°C. The irradiance is 1000 W/m². PV-3 has a total output capacity of 3000 W, which is higher than the 2000 W of PV-1 and PV-2. The (I-V) and (P-V) characteristics of a particular photovoltaic panel are depicted in Figure 9. The PV-1 and PV-2 systems are comprised of ten solar panels that are connected in parallel, resulting in an output of 37.26 V and 53.7 A (10×5.37 A). PV-3 consists of fifteen solar modules that are arranged in parallel. The output voltage is 37.26 V, and the current is 80.55 A (15 × 5.37 A). The output voltage and current

of three photovoltaic systems are depicted in Figure 10. The circuit design of a boost converter that was implemented in Matlab is depicted in Figure 11.

The boost converter's duty cycle (D) is as follows:

$$D = 1 - \frac{V_{in}}{V_{out}}$$

The boost converter inductor and output capacitor have the following dynamics:

$$L_{min} = \frac{D(1-D)^2 R}{2f}$$

$$C = \frac{D}{R \left(\frac{\Delta V_O}{V_O} \right) f}$$

where the

$\left(\frac{\Delta V_O}{V_O} \right)$ Output ripple voltage is 1%, output resistance is R, and frequency is f.

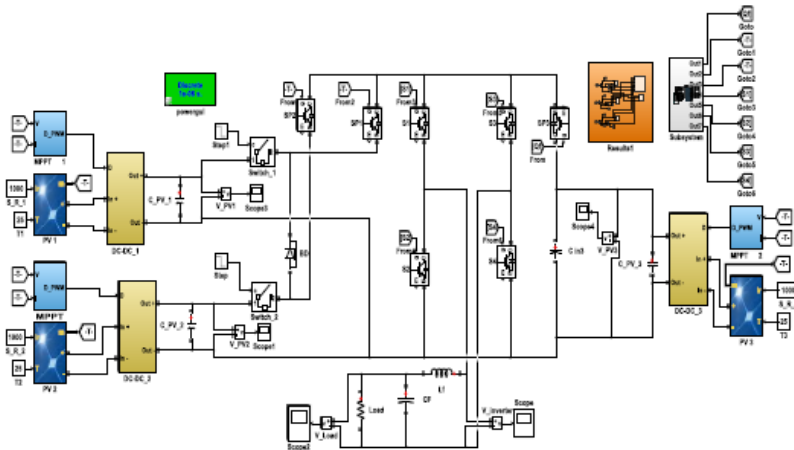

Figure1. Proposed system implemented in the MATLAB program

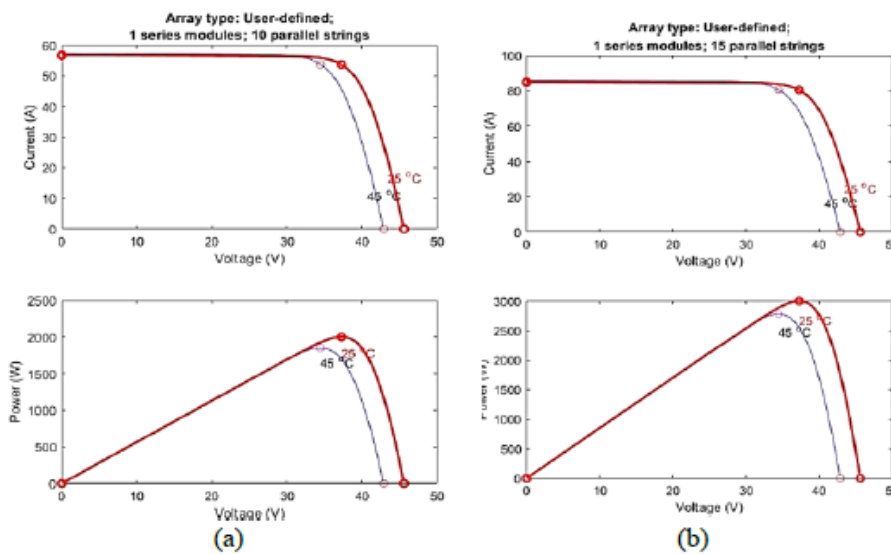

Figure2. The (I-V) and (P-V) behavior of PV systems for (a) PV-1 and PV-2, (b) PV-2 and PV-33

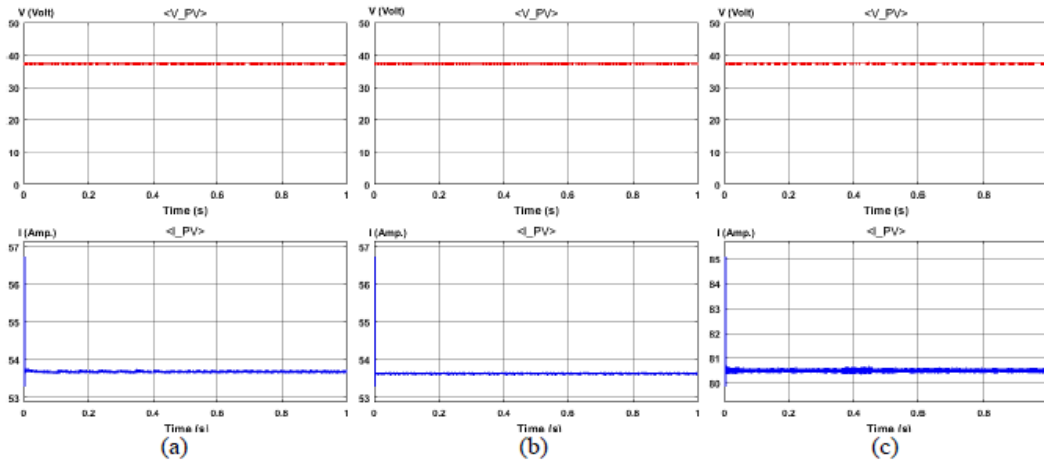

Figure3. Output voltage and current output of (a) PV systems, for (b) PV-1 and PV-2, and (c) PV-3

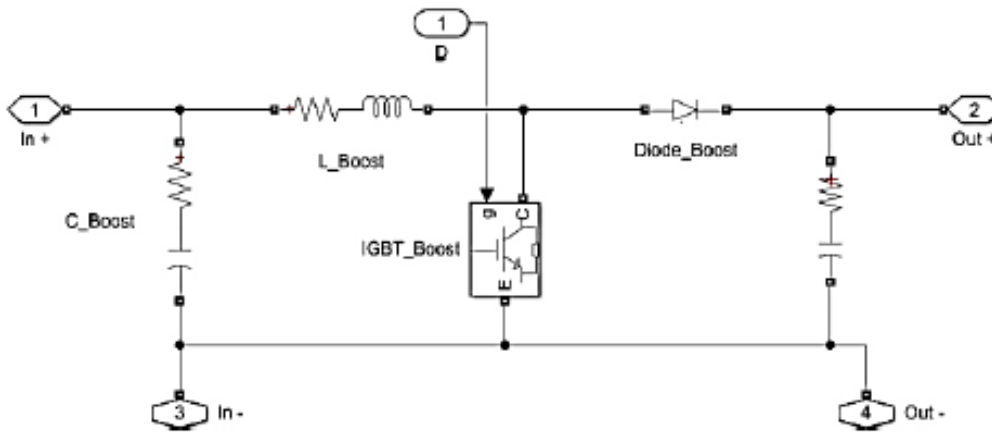

Figure4. Boost converter design in MATLAB

The photovoltaic submodules (PV-1, PV-2, and PV-3) are arranged in series with the switches (Sp1, Sp2, and S3). The load voltage is achieved by the distinct functions of the switch pairs (S1, S4) and (S2, S3). Three photovoltaic (PV) systems are connected by a multi-layer interconnect (MLI) that contains seven switches. The PV-3 voltage V_{dc} (400 V) is precisely equivalent to the output voltage in this instance. The output voltage of PV-3 is the sum of PV-1 ($1/3 \times 400 = 133.3$ V) and PV-2 ($2/3 \times 400 = 266.6$ V). A seven-level voltage waveform devoid of an LC filter is depicted in Figure 12. Figure 13 illustrates the equivalent waveform that is achieved through the use of an LC filter.

Total harmonic distortion (THD) quantifies the ratio of the total aggregate power of harmonic components to the power of the fundamental frequency [30]–[33]. Total harmonic distortion (THD) is a metric that assesses the linearity of a system and the quality of its power. The total harmonic current distortion for a rated inverter output must be significantly less than 5% of the fundamental frequency current, as per IEEE regulations. The output voltage's total harmonic distortion (THD) was 16.7% when an LC filter was present, as opposed to 1.13% when it was absent. LC filters are intended to reduce harmonics. The MATLAB software generates the Total Harmonic Distortion (THD) using the LC filter, as illustrated in Figure 14.

The overall resilience of a system that consists of numerous photovoltaic systems is contingent upon contingency analysis. Even if PV-1 is decommissioned, the system will continue to operate and deliver the specified output voltage. This voltage will decrease from seven to five levels as the THD increases. The output voltage is depicted in Figure 15 when PV-1 is inactive for 0.5 seconds in the absence of an LC filter. PV-2 and PV-3 resulted in a 3.51% increase in the THD of the five-level inverter. PV-2 is dormant in the absence of an LC filter, as illustrated in Figure 16. The five-level inverter, which utilizes PV-1 and PV-3, demonstrates an improved THD of 4.19%. When all photovoltaic systems are operational, the output has seven voltage levels and a total harmonic distortion of 1.13%.

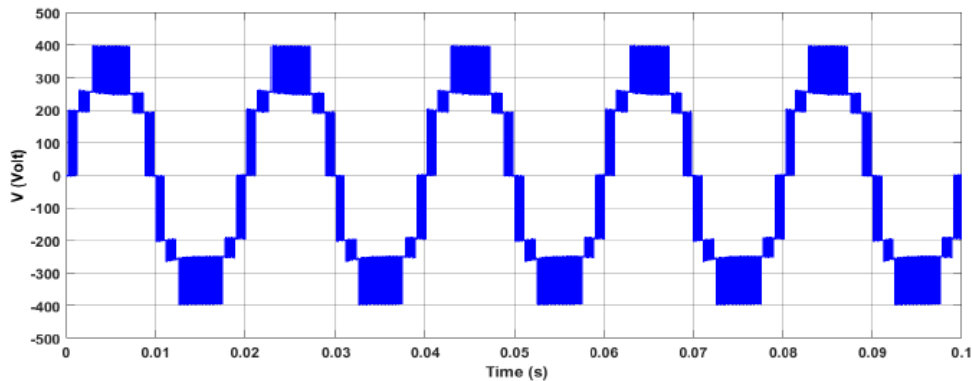

Figure 12. A waveform with seven levels and no LC filter

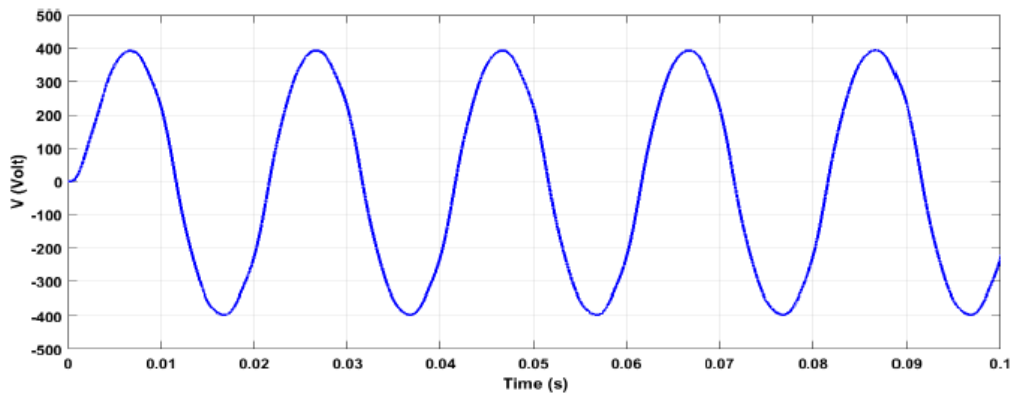

Figure13. A waveform with seven levels with an LC filter

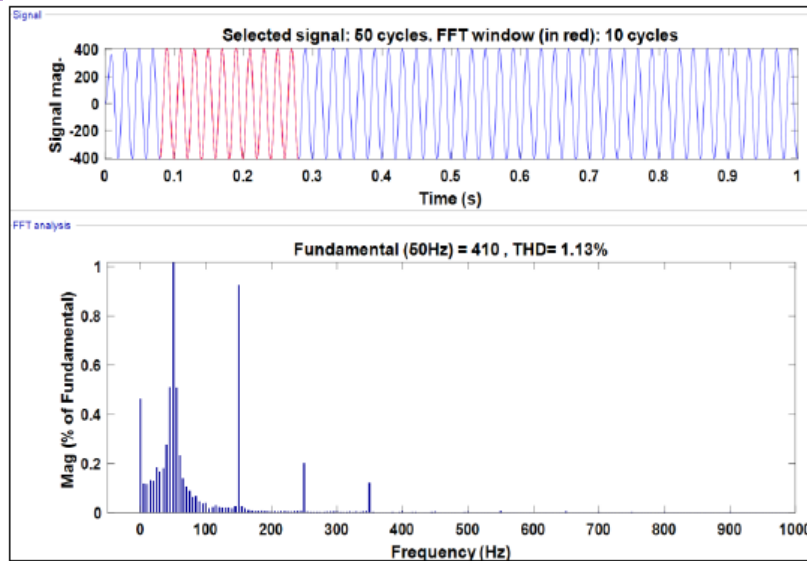

Figure14. THD designed using the MATLAB program

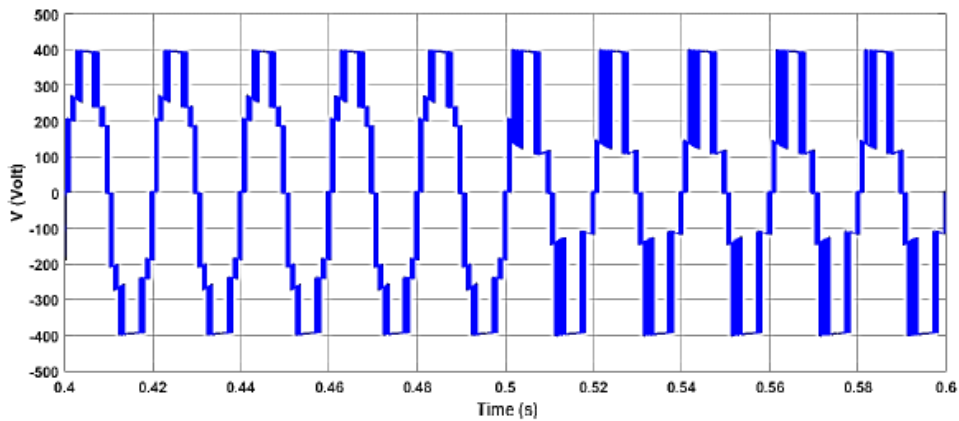

Figure 15. Transitioning from seven to five output voltage levels in the case of a PV-1 outage

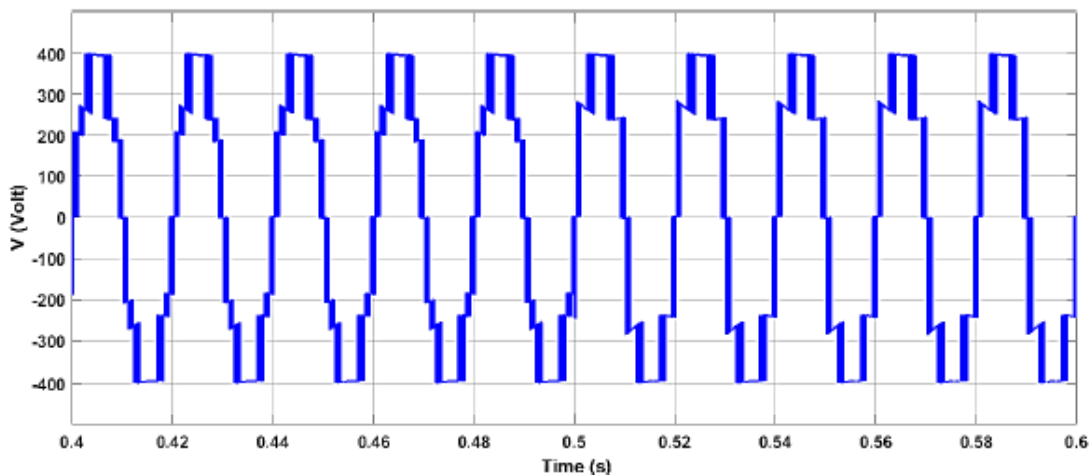

Figure 16. Transitioning from seven to five output voltage levels in the case of a PV-2 outage

5. CONCLUSION

The proposed architecture significantly improves power quality, efficiency, and voltage regulation, while concurrently reducing circuit complexity, as evidenced by the performance

evaluation of a streamlined multilayer converter for off-grid solar systems. Harmonic distortion is reduced and system reliability is improved by employing effective control methodologies and employing a reduced number of switching components. The converter is appropriate for independent solar applications in remote areas due to its cost-effectiveness and scalability. The research indicates that the simplified multilayer converter is a reliable method for guaranteeing energy conversion in off-grid solar applications.

REFERENCES

- [1] M. Hassan and T. Brooks, "Simplified multilevel converters for enhanced performance of off-grid solar systems," *IEEE Access*, vol. 13, pp. 1–10, 2025,
- [2] K. T. Nguyen, "Performance analysis of multilevel converters under varying irradiance in off-grid solar applications," *IEEE Transactions on Power Electronics*, vol. 39, no. 4, pp. 3500–3512, Apr. 2024,
- [3] R. Almeida and P. Costa, "Design of a compact multilevel converter with optimized switching for solar energy systems," *IEEE Transactions on Sustainable Energy*, vol. 14, no. 2, pp. 1200–1210, Apr. 2023,
- [4] F. Khan and S. Ibrahim, "Comparative analysis of multilevel converter configurations for standalone photovoltaic systems," *IEEE Journal of Emerging and Selected Topics in Power Electronics*, vol. 10, no. 3, pp. 2100–2110, Jun. 2022,
- [5] J. Lopez and S. Park, "Performance evaluation of simplified multilevel converters for off-grid solar applications," *IEEE Transactions on Industrial Electronics*, vol. 68, no. 9, pp. 8500–8510, Sept. 2021,