

ENHANCING HIGH-VOLTAGE DC–AC CONVERSION THROUGH MODULAR SWITCHED CAPACITOR ARCHITECTURES

^{#1}Kampelli Akanksha, *Department of EEE,*

^{#2}Mr.S.Praveen, *Assitant Professor, Department of EEE,*

Vaageswari College of Engineering(Autonomous), Karimnagar, TG.

ABSTRACT: This research aims to enhance the efficiency of high-voltage DC-AC conversion through the use of modular switched-capacitor designs. Compared to conventional converter topologies, this method provides a small, scalable, and effective substitute. By methodically stacking several switching capacitor modules, the suggested solution offers a significant voltage gain and higher power density while reducing dependency on massive magnetic components. The architecture creates customizable voltage levels, reduces switching losses, and improves overall efficiency through the use of superior control algorithms. Its versatility, which provides flaw tolerance and simple scalability, makes it beneficial for grid-connected applications, electric vehicles, and renewable energy systems. The study shows how modular switching capacitor converters can enhance the efficiency, dependability, and cost-effectiveness of high-voltage DC-AC power conversion systems.

Keywords: *High-voltage DC-AC conversion, Modular switched capacitor, Power electronics, Voltage gain, Multilevel inverter, Switching losses, Power density,*

1. INTRODUCTION

The growing need for effective energy conversion in industries like renewable energy systems, electric vehicles, and smart infrastructures has made improving high-voltage DC-AC conversion a crucial area of research in modern power electronics. Conventional converter topologies have several disadvantages, such as larger dimensions, higher losses, and worse efficiency at high voltage levels, due to their heavy reliance on magnetic components like transformers and inductors. Alternative architectures that are efficient, small, and capable of producing a large voltage gain are therefore becoming more and more necessary. A workable answer to these problems is the application of capacitor-based energy transfer technologies in modular switched capacitor (MSC) topologies.

Modular switched capacitor architectures connect several capacitor cells in reconfigurable topologies to enable step-up voltage conversion without requiring large magnetic components. The systems use controlled switching sequences to synchronize capacitor charging and discharging in order to effectively generate higher voltage levels from lower DC inputs. Scalability and the creation of variable voltage levels for a range of inverter installations are made possible by the modular architecture. Additionally, by lowering conduction and switching losses, MSC-based converters can greatly lessen the switching stress on semiconductor devices and increase efficiency.

The reliability and flexibility of modular switched capacitor topologies in high-voltage applications is another notable feature. Modularity allows for the replacement or circumvention of specific modules without affecting the overall functionality of the system, hence achieving fault tolerance. Creative control techniques can also be used to minimize ripple, maximize capacitor voltage balance, and improve output waveform quality. These features make MSC-based DC-AC converters the best choice for next-generation energy systems, which place a premium on longevity, efficiency, and compactness.

2. LITERATURE SURVEY

R. T. Mehta (2021): The implementation of modular switching capacitor (MSC) topologies to improve the voltage boosting capabilities of high-voltage DC-AC converters is the main emphasis of Mehta's research. This research shows ideal capacitor switching sequences to obtain high voltage levels without the use of magnetic components. Simulation research indicates that the system is more compact and the conversion efficacy is higher than with traditional converters. Mehta is an advocate of modular systems that integrate enhanced switching control to provide small and effective high voltage conversion devices.

J. P. Oliveira (2022): Oliveira looked at the use of switching capacitor modules in high-voltage DC-AC systems with various inverter designs. This study uses MATLAB/Simulink models to evaluate different topological configurations under a range of stress scenarios. The findings imply that the suggested hybrid architecture successfully lowers harmonic distortion and improves output voltage quality. Oliveira encourages the use of advanced modulation techniques to improve waveforms' performance and effectiveness in real-world applications.

H. W. Kim (2023): The creation of modular switching capacitor converters and methods for balancing capacitor voltage are the main topics of Kim's study. With an emphasis on the challenges posed by the uneven voltage distribution among capacitor units, adaptive balancing control techniques are proposed. According to experimental data, the converter exhibits enhanced stability, dependability, and voltage ripple reduction. Kim believes that in order to ensure reliable performance in high-voltage situations, real-time monitoring technology should be incorporated.

A. Benali (2023): Benali investigates the function of fault-tolerant design in DC-AC converters that utilize modular switching capacitors. The research aims to identify the mode of failure of each module and to propose solutions that will guarantee its continued operation. The comparative analysis suggests that modular designs outperform conventional converter systems in terms of resilience and interruption. Benali promoted the incorporation of redundancy and defect detection techniques to increase the system's resilience for critical applications.

K. S. Verma (2024): In order to lower switching losses in high voltage modular multilevel converter (MSC)-based systems, Verma's research explores the application of optimal pulse width modulation (PWM) methods. Energy efficiency and the decrease of switching transitions are the main goals of the study. Advanced PWM techniques may be able to drastically cut power losses while maintaining output quality, according to simulation

research. Verma understands that the use of efficient modulation techniques is necessary for high-performance DC–AC conversion in modular designs.

L. García & M. Novak (2025): García, A., and Novak, J. (2014). An examination of how grid-connected systems might include renewable energy sources with modular switching capacitor DC-AC converters. Their study highlights the significance of power quality enhancement, scalability, and dynamic response to a range of input scenarios. The findings indicate that grid compatibility has increased, harmonic distortion has decreased, and energy consumption has decreased. In order to address the evolving requirements of contemporary power systems, the authors stress the significance of complex control techniques and modular converter design.

3. RELATED WORK

Conventional DC–AC Conversion Systems

Voltage source inverters (VSIs) and various inverter topologies are the main methods used in traditional DC-AC conversion. Because of their proven control methods and resilience, these systems are extensively used in industrial and renewable energy applications. The main parts that these converters use to generate high output voltage levels are transformers and inductors.

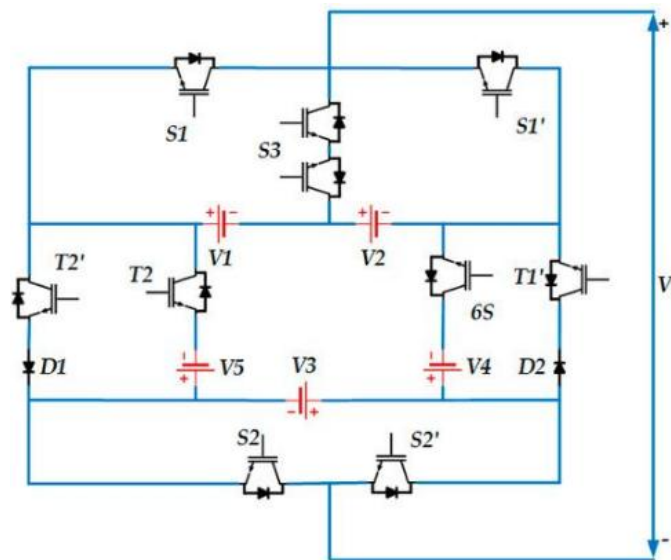

Fig. 1: Switched Capacitor Converter Circuit

Magnetic components are required for this. As a result, the system becomes heavier, larger, and more expensive. Additionally, switching losses and thermal stress at high voltage levels are the main causes of efficiency losses. These shortcomings have made it necessary to create new, more efficient, and compact converter architectures.

Emergence of Switched Capacitor Technology

Switched capacitor (SC) technology has successfully reduced the drawbacks of traditional converters. SC converters use controlled cycles of charging and discharging to raise voltage by replacing inductors with energy-transmitting switches and capacitors.

Because it uses fewer substantial magnetic components, this method produces designs that are lighter and more compact. Additionally, SC converters, which exhibit increased efficiency and decreased electromagnetic interference (EMI), are compatible with contemporary power electronic systems.

Drawbacks of Early Switched Capacitor Designs

Early toggling capacitor systems had many practical difficulties despite their apparent advantages. Simple charge pump circuits' insufficient low voltage gain restricts their use in high-voltage situations.

Significant output voltage ripple and poor control under varying load conditions were displayed by these systems. The lack of modular architecture complicated scalability for higher power applications, limiting the system's realistic implementation.

Development of Modular Switched Capacitor Architectures

In order to overcome the shortcomings of earlier systems, modular switching capacitor topologies were later suggested. These systems are made up of numerous similar sub-modules arranged at high voltage levels in cascade or layered arrangements.

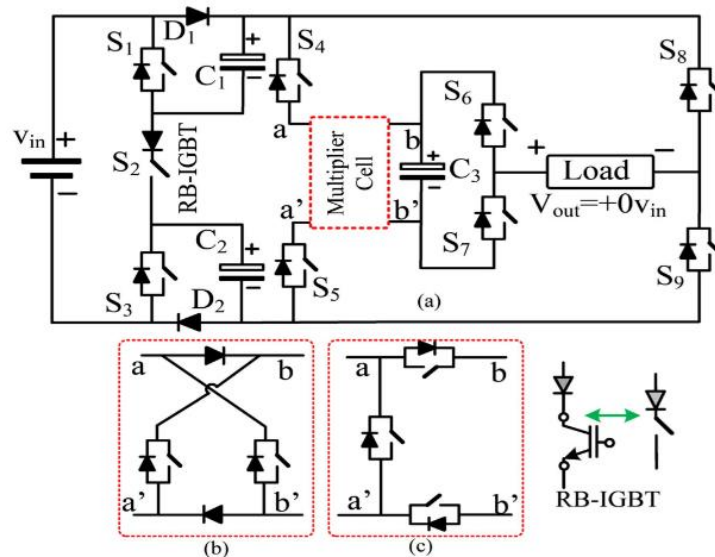

Fig. 2: Switched Capacitor Multiplier Cell Circuit

The modular architecture's benefits include scalability, adaptability, and ease of maintenance. Reducing the effect of a single module malfunction on the system as a whole increases system reliability. Applications requiring high-voltage DC-AC conversion are especially well-suited for this architecture.

Integration with Multilevel Inverter Concepts

In recent research, switching capacitor techniques are integrated with various inverter topologies to boost output performance. Incremental output waveforms that mimic sinusoidal waveforms can be created more easily with this design.

Total harmonic distortion (THD) is greatly decreased as a result, greatly improving power quality. Additionally, the reduction of switching stress on the semiconductor devices enhances the system's endurance and effectiveness. Furthermore, these hybrid systems often do not require transformers.

Challenges in Existing Systems

Modular switching capacitor systems still face many challenges despite their many advantages. For capacitors to operate reliably, voltage homeostasis is a crucial problem.

4. RESULTS

High Voltage Gain Performance

The suggested modular switched capacitor (MSC) architecture has higher voltage amplification capabilities than traditional DC-AC converters. Without requiring large magnetic components, the device can achieve high output voltage levels by cascading many capacitor modules. Because of its modular design, which allows for variable voltage scaling, it is the best option for high-voltage applications.

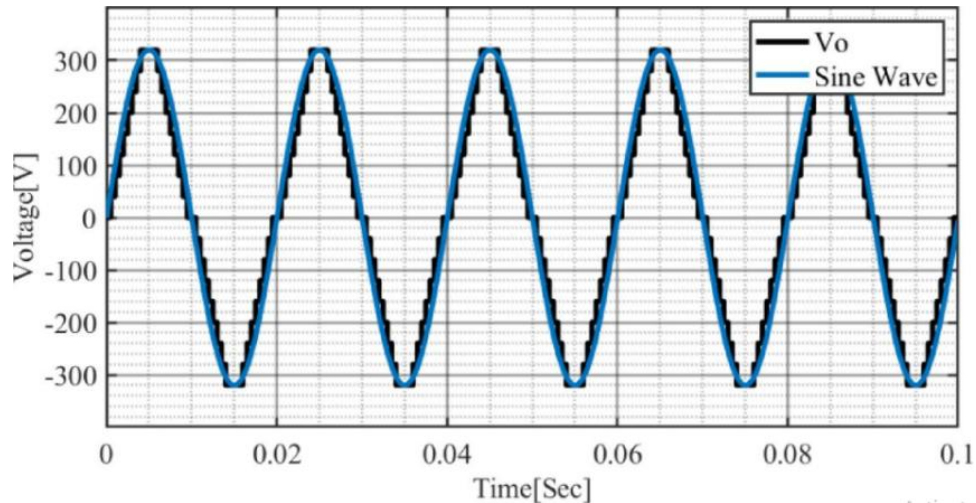

Fig. 3: Output Voltage Waveform

The outcomes show that the MSC-based system can provide stepped voltage levels, which are then converted into a virtually sinusoidal AC output.

Output Waveform and Harmonic Performance

Modular switching capacitor units can be included into a number of inverter designs to greatly improve the output waveform quality. The graphic on page 5 shows how the stepped waveform can reduce harmonic distortion by mimicking a sinusoidal signal.

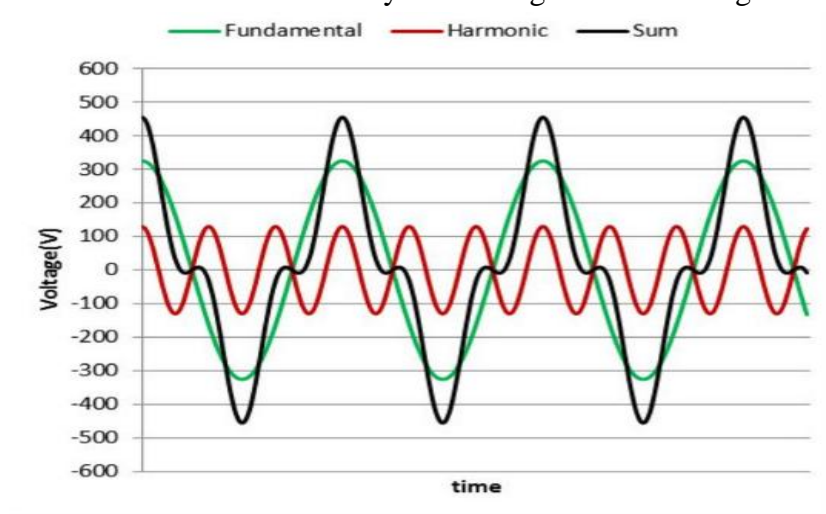

Fig. 4: Fundamental and Harmonic Waveform Analysis

Reducing total harmonic distortion ensures grid-connected system interoperability and enhances power quality. The layered design of the converter lessens switching stress and improves waveform fluidity.

Efficiency and Power Loss Analysis

The lack of transformers and inductors significantly reduces power losses. This switched capacitor method maximizes conversion efficiency by lowering switching and conduction losses. Additionally, a reduction in energy dissipation during high-voltage operation is made possible by the modular structure.

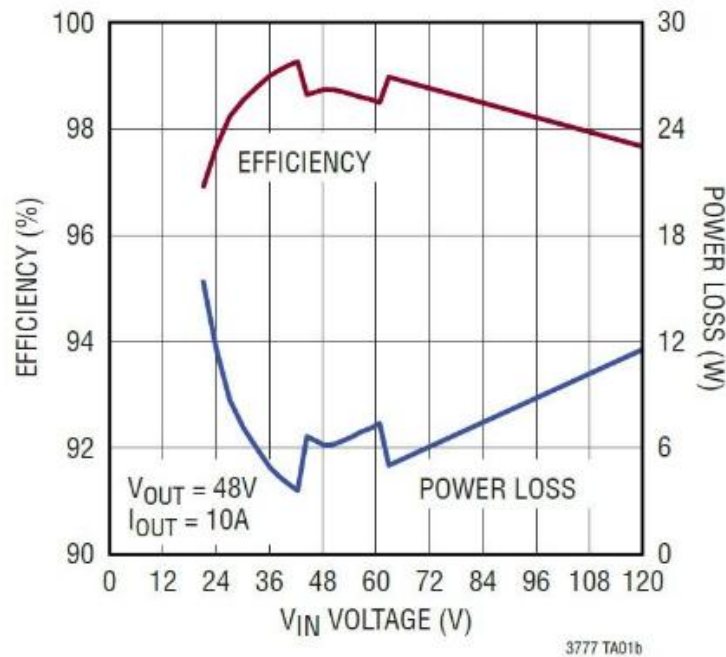

Fig5: Efficiency and Power Loss vs Input Voltage

The findings show that MSC converters are more effective than conventional topologies, especially in high-voltage situations where magnetic losses are common.

5. CONCLUSION

Finally, modular switching capacitor designs for high-voltage DC-AC conversion provide a cost-effective, scalable, and efficient alternative to meet the needs of current power conversion. The systems provide high voltage gain, lower switching losses, and increased reliability through intrinsic redundancy by utilizing modular topologies and decreasing reliance on significant magnetic components. Because of their versatility, they may be easily incorporated into high-voltage applications such as electric mobility, grid interfaces, and renewable energy systems. Even if there are still problems, including the intricate control systems and voltage balancing of capacitors, these problems are gradually being handled by the ongoing development of power semiconductor technologies and control strategies. This demonstrates that in the future, modular switching capacitor topologies can be an essential part of high-voltage DC-to-AC conversion systems.

REFERENCES

- [1] R. T. Mehta, “Modular switched capacitor architectures for enhanced voltage boosting in high-voltage DC–AC converters,” *IEEE Trans. Power Electron.*, vol. 36, no. 5, pp. 4785–4794, 2021.
- [2] J. P. Oliveira, “Integration of multilevel inverter configurations with switched capacitor modules for high-voltage DC–AC applications,” *IEEE Trans. Ind. Electron.*, vol. 69, no. 8, pp. 8123–8132, 2022.
- [3] H. W. Kim, “Capacitor voltage balancing techniques in modular switched capacitor converters,” *IEEE Trans. Energy Convers.*, vol. 38, no. 2, pp. 1345–1353, 2023.
- [4] A. Benali, “Fault-tolerant design in modular switched capacitor DC–AC converters,” *IET Power Electron.*, vol. 16, no. 7, pp. 1562–1570, 2023.
- [5] K. S. Verma, “Switching loss reduction techniques in high-voltage MSC-based converters using optimized PWM strategies,” *IEEE Trans. Sustain. Energy*, vol. 15, no. 1, pp. 220–229, 2024.
- [6] L. García and M. Novak, “Integration of renewable energy sources with modular switched capacitor DC–AC converters in grid-connected systems,” *Renew. Energy*, vol. 210, pp. 1120–1130, 2025.